



**INTERNATIONAL JOURNAL OF ENGINEERING SCIENCES & RESEARCH
TECHNOLOGY**

TRANSMISSION OF WIRELESS POWER IN MEDICAL FIELD

Shivanand Mishra*, Purushotam Tewari, Sandeep Kumar, K.Subbulakshmi, A.Geetha

* UG Student, Dept. of Electronics and Communication Engineering, Bharath University, India.

UG Student, Dept. of Electronics and Communication Engineering, Bharath University, India.

UG Student, Dept. of Electronics and Communication Engineering, Bharath University, India.

Asst. Professor, Dept. of Electronics and Communication Engineering, Bharath University, India.

Asst. Professor, Dept. of Electronics and Communication Engineering, Bharath University, India.

ABSTRACT

It's characterised by period and multi-rate operations outline the ways that during which the system works, reacts to events and interrupts and schedules the system's functioning in real time. It will therefore by following a concept to regulate latencies and to satisfy deadlines. the various operations could happen at distinct rates. The user of associate embedded device is usually not even aware that a laptop is gift within the device. the pc is employed primarily to supply flexibility and to modify the system style. in contrast to a laptop, program code is typically hold on in computer storage and not a tough disc drive. Typically, the tip user doesn't develop new package for the embedded device. With advances in VLSI technology, embedded systems became therefore cheap that they're found in most of today's electronic devices.

KEYWORDS: Wireless Power Transfer, High Frequency Power Transmission, Mutual coupling ,blood pressure device

INTRODUCTION

Since wireless power transfer technology (WPT) gains its quality, broad vary of application and analysis area unit performed within the field of medical implantable applications. during this paper, we tend to review the technical standing of WPT system applied to medical implant devices. As a utilization of this technology, this achievements and challenges of wireless capsule scrutiny area unit reviewed and analyzed, in sight of its style, useful demand and connected problems in WPT. And WPT application to implant is additionally mentioned. primarily based upon the analysis, we tend to propose a research directions and WPT thought in coming up with a WPT system for implantable medical applications.

MATERIALS AND METHODS

Proposed System

Here we tend to area unit attending to see Medical Implantable Applications victimisation WPT (Wireless Power Transfer). AC provide are given HF (High Frequency) electrical device, in order that electrical device will turn out high magnetic flux within the primary aspect. it'll be transferred to secondary aspect and victimisation filters it's given to DC regulator with facilitate of regulator, provide are given to Microcontroller. And {blood pressure|vitalsign|pressure|pressurelevel|force per unit area unita} values are transmitted through zigbee and monitor victimisation laptop.

BLOCK DIAGRAM:-
WPT TRANSMITTER SECTION:

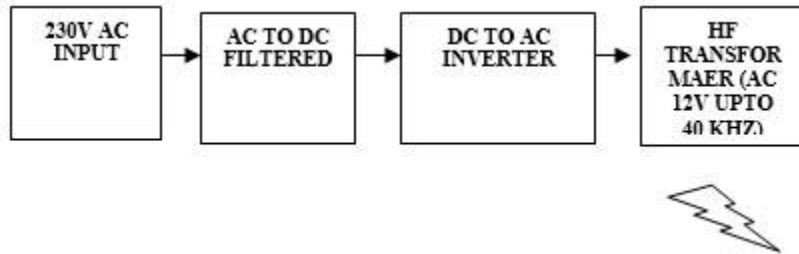

WPT RECEIVER AND PATIENT SECTION:-

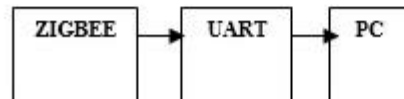
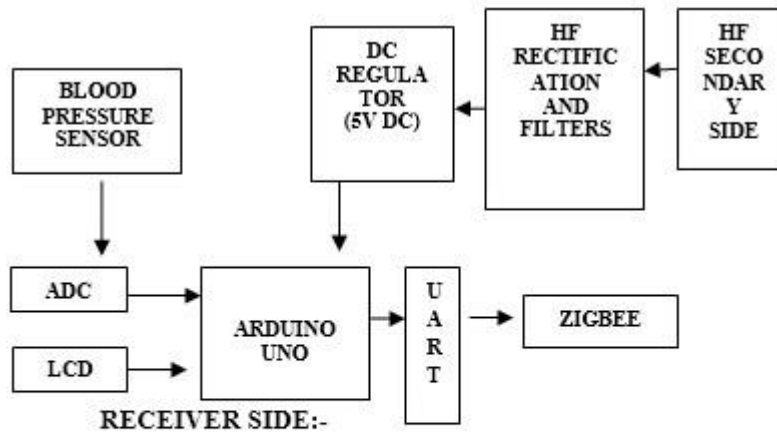

Figure one block diagram

OPERATING OF THE PROJECTED SYSTEM

Alternating current 230V, fifty Hertz mains is ventured all the way down to low potential unitage AC by routine fifty Hertz iron cored electrical device that is then amended by associate extension rectifier to grow around fourteen volt DC. This DC is once more created to AC by a PWM electrical converter utilizing [*fr1] extension plan embodying two MOSFETs and a pair of capacitors being changed at forty kilocycle that is then sustained to a resounding high repetition loop going regarding as essential of associate air center electrical device. associate alternate coordinating resounding loop structured as auxiliary drives a heap separated at associate air separation of

forty CMs. the final effectiveness of the facility transfer for this example is over ninetieth for cleanly coupled and coordinated arrangement resonators. even so, primarily resonators with a letter of one,000 have to be compelled to have the capability to send management over a separation nine times the span of the gadgets with associate effectiveness of 100 percent.

High frequency transformers

The uses of high frequency transformers embody wattage transmission over long distances.

High-voltage direct-current HVDC power transmission frameworks. Some Large, exceptionally

developed force transformers area unit utilised for electrical curve heaters utilised as a region of steelmaking. Turning transformers area unit composed with the goal that one retardation down whereas alternate stays stationary. Common use was the video head system as utilized in VHS and Beta video tape players.

The high frequency transformers used here area unit accustomed step down the voltage from a high voltage to an occasional voltage.



Figure two High frequency transformers

Voltage regulators

A transformer is employed wherever the system is in want of fastened or constant output voltage .the voltage regulators used here area unit 7808 and 7815 area unit utilized in the output and input aspect severally. The voltages on the market enable these regulators to be utilized in logic systems, instrumentation and alternative electronic convenience or instrumentation. These regulators are often created to get adjustable voltages and currents external elements for varied alternative applications.

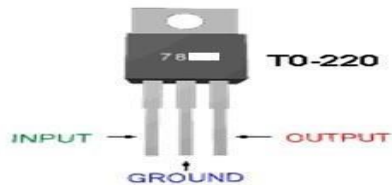

Figure three Series Voltage Regulators

Pulse breadth Modulators (SG3524)

The SG3524 has constitutional all the specified functions for maintaining power provides inverters or any switch devices. Their main application is for top power-output functioning .it are often used as one – ended or for push-pull applications whichever necessary. The operation of the IC is completed by the temporal order resistance and electrical device. and therefore the IC has constitutional 5v transformer for reference purpose.it has additionally generator, error electronic equipment flip-flops etc.



Figure four PWM IC

Blood pressure sensor:-

The following may be a partial list of activities and experiments that may be performed using this device.

- Measure blood pressure before and after exercise.
- Measure blood pressure while sitting or standing.
- Compare blood pressure after voluntary isometric contractions (weight lifting) and a rhythmic activity such as running or biking.
- Investigate how digestion affects blood pressure.
- Study the effect of caffeine on blood pressure.
- Compare blood pressure between smokers and non-smokers.

What is included with the Blood Pressure Sensor?

- Blood Pressure Sensor
- Standard adult size adjustable cuff (27 cm to 39 cm)
- Bulb pump (with release valve)
- Blood Pressure Sensor booklet (this booklet)

How the Blood Pressure Sensor Works

The active sensor in this unit is the SenSym SDX05D4 pressure transducer. It has a membrane which flexes as pressure changes. This sensor is arranged to measure differential pressure. The sensor produces an output voltage which varies with the pressure measured in the cuff. It includes special circuitry to minimize errors caused by changes in temperature. We provide an amplifier circuit that conditions the signal from the pressure transducer. With this circuit, the output voltage from the Blood Pressure Sensor will be linear with respect to pressure.



Figure five Blood pressure sensor

Arduinoboard :-

Foundations

Elements of the Arduino hardware and software .

Basics

Sketch: The various components of a sketch and how they work.

Microcontrollers

Digital Pins: How the pins work and what it means for them to be configured as inputs or outputs.

Analog Input Pins:

Details about the analog-to-digital conversion and other uses of the pins.

PWM:

How the analogWrite() function simulates an analog output using pulse-width modulation.

Memory: The various types of memory available on the Arduino board.

Arduino Firmware

Bootloader: A small program pre-loaded on the Arduino board to allow uploading sketches.

Programming Technique

Variables: How to define and use variables.

Port Manipulation: Manipulating ports directly for faster manipulation of multiple pins

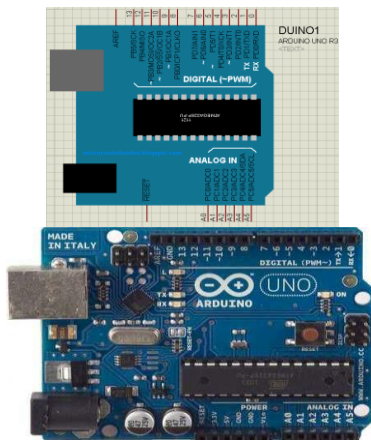

Figure 6 Arduino board

Wireless power transfer waveform :-

The idea of transmitting power through the air has been around for over a century, with Nikola Tesla's pioneering ideas and experiments perhaps being the

most well-known early attempts to do so [1]. He had a vision of wirelessly distributing power over large distances using the earth's ionosphere. Most approaches to wireless power transfer use an electromagnetic (EM) field of some frequency as the means by which the energy is sent. At the high frequency end of the spectrum are optical techniques that use lasers to send power via a collimated beam of light to a remote detector where the received photons are converted to electrical energy. Efficient transmission over large distances is possible with this approach; however, complicated pointing and tracking mechanisms are needed to maintain proper alignment between moving transmitters and/or receivers. In addition, objects that get between the transmitter and receiver can block the beam, interrupting the power transmission and, depending on the power level, possibly causing harm. At microwave frequencies, a similar approach can be used to efficiently transmit power over large distances using the radiated EM field from appropriate antennas .

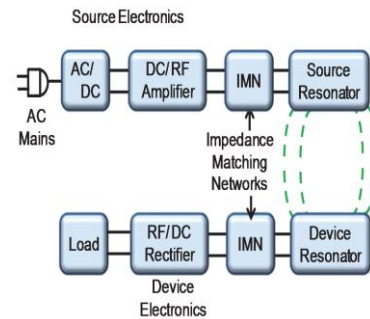

Fig. 8. Waveforms at 22 V, 6.639 Hz into a 23.6 Ω load for the MOSFET setup.

Figure 7 WPT block diagram & amp; waveform

This system involves three modules. They are the transfer section, collector section ,reciver section and controlled by pc section. The introduced system is a simple and low-cost and can be easily implemented and installed in medical implantation can be of use in hospital. The system will require a high frequency transformer, pulse width modulator, inductive coils and blood pressure sensor,zigbee as their major parts for its working.

WPT transmitter section, WPT receiver and patient section ,receiver side section.

RESULTS AND DISCUSSION

Based on exploratory result, the Mutual Coupling Analysis of wireless power transmission with self regulated output voltage for biomedical implant has much perspective in separation, scope of recurrence and result demonstrates that closer the separation, the voltage transferred is higher.

The distance at which the power can be transmitted without much distortion is 40 cm with 5 Volt at the output for blood pressure sensor.

The wireless power transfer is very little influenced by protecting materials, for example, the vicinity of human body, cardboards, plastic materials and so forth.

The outcome also demonstrates, the wireless power transfer suitably actualizes for medical implant and within a reasonable distance.

CONCLUSION

This paper has concluded designing, developing and building a simple wirelessly transferring power medical field's active and passive components and sensors .The Mutual Coupling Analysis of wireless power transfer with the application in medical field has been built and test have been carried out for the analysis of the system. The system developed is expected to continue to deliver power for the proper functioning in times of need. It is envisaged that the system is able to overcome the problem of manual in medical implant. And it controlled by the personal computer.

REFERENCES

- [1] M. Catrysse, B. Hermans and Robert Puers, "An Inductive Power System with Integrated Bi-directional Data Transmission," *Sensors and Actuators*, vol. A115, pp. 221-229, September, 2004.
- [2] C. M. Zierhofer and E. S. Hochmair, "Geometric Approach for Coupling Enhancement of Magnetically Coupled Coils," *IEEE Trans. Biomed. Eng.*, vol. 43, pp. 708-714, July, 1996.

- [3] R. R. Harrison, "Designing Efficient Inductive Power Links for Implantable Devices," *ISCAS 2007, LA, May, 2007*.
- [4] U. M. Jow and M. Ghovanloo, "Design and Optimization of Printed Spiral Coils for Efficient Transcutaneous Inductive Power Transmission," *IEEE Trans. Biomed. Circuit Sys.*, vol. 1, pp. 193-202, September, 2007.
- [5] T. Sun, X. Xie and Z. Wang, *Wireless Power Transfer for Medical Microsystems*, New York, Springer, 2013.
- [6] B.-L. Ooi, D.-X. Xu, P.-S. Kooi and F. Lin, "An Improved Prediction of Series Resistance in Spiral Inductor Modeling with Eddy-Current Effect," *IEEE Trans. Micro. Theory Techn.*, vol. 50, pp. 2202-2206, September, 2002
- [7] S. O'Driscoll, A. Poon and T.-H. Meng, "A mm-sized Implantable Power Receiver with Adaptive Link Compensation," *ISSCC, San Francisco*, February, 2009.
- [8] Chong, S.S. & Chan, P.K. (2012). "A 0.9 uA Quiescent Current Output-Capacitorless LDO Regulator with Adaptive Power Transistors in 65 nm CMOS," *IEEE Trans. Circuits Syst. I*, vol. 1, pp. 1072-1081, April, 2013.
- [9] C. Chae, H. Le, K. Lee, G. Cho and G. Cho, "A Single-Inductor Step-up DC-DC Switching Converter with Bipolar Outputs for Active Matrix OLED Mobile Display Panels," *IEEE J. Solid-State Circuits*, vol. 44, pp. 509-524, February, 2009.
- [10] A. Salim, M. Martin, C. Brown, H. Belzberg, P. Rhee and D. Demetriades, "Complications of Brain Death: Frequency and Impact on Organ Retrieval," *The American Surgeon*, vol. 72, pp. 377-381, May, 2006.
- [11] M. W. Baker and R. S. Sarpeshkar, "Feedback Analysis and Design of RF Power Links for Low-Power Bionic Systems," *IEEE Trans. Biomed. Circuit Sys.*, vol. 1, pp. 28-38, March, 2007.
- [12] G. Wang, W. Liu, M. Sivaprakasam, M. Zhou, J. D. Weiland and M. S. Humayun, "A Dual Band Wireless Power and Data Telemetry for
- [13] Retinal Prosthesis," *28th EMBS Annual International Conference*, New York, August, 2006.